

Deltran Battery Tender® Selectable
NORTH AMERICAN MODELS ONLY
*Designed for six-cell lead-acid batteries
 and three-cell lead-acid batteries*

Deltran Battery Tender® Selectable
For FOREIGN COMPLIANCE
*Designed for six-cell lead-acid batteries from 1.2 – 200Ah
 and three-cell lead-acid batteries from 1.2 – 200Ah*

IMPORTANT SAFETY INSTRUCTIONS

- 1) SAVE THESE INSTRUCTIONS – This manual contains important safety and operating instructions for battery charger model P/N 022-0211.
- 2) Do not expose charger to rain or snow.
- 3) Use of an attachment not recommended or sold by the battery charger manufacturer may result in a risk of fire, electric shock, or injury to persons.
- 4) To reduce risk of damage to electric plug and cord, pull by plug rather than cord when disconnecting charger.
- 5) An extension cord should not be used unless absolutely necessary. Use of improper extension cord could result in a risk of fire and electric shock. If an extension cord must be used, make sure:
 - a) That pins on plug of extension cord are the same number, size, and shape as those of plug on charger;
 - b) That extension cord is properly wired and in good electrical condition; and
 - c) That wire size is large enough for ac ampere rating of charger as specified in Table 1

TABLE 1

Length of Cord, Feet/Meters	25/7.6	50/15.2	100/30.5	150/45.7
AWG Size of Cord	18	18	18	16

- 6) Do not operate charger with damaged cord or plug – replace the cord or plug immediately.
- 7) Do not operate charger if it has received a sharp blow, been dropped, or otherwise damaged in any way; take it to a qualified serviceman.
- 8) Do not disassemble charger; take it to a qualified serviceman when service or repair is required. Incorrect reassembly may result in a risk of electric shock or fire.
- 9) To reduce risk of electric shock, unplug charger from outlet before attempting any maintenance or cleaning. Turning off controls will not reduce this risk.
- 10) When replacing the fuse in the accessory cable use an AB19, 7.5Amp or equivalent type fuse.
- 11) **WARNING – RISK OF EXPLOSIVE GASES.**
 - a) WORKING IN VICINITY OF A LEAD-ACID BATTERY IS DANGEROUS. BATTERIES GENERATE EXPLOSIVE GASES DURING NORMAL BATTERY OPERATION. FOR THIS REASON, IT IS OF UTMOST IMPORTANCE THAT YOU FOLLOW THE INSTRUCTIONS EACH TIME YOU USE THE CHARGER.
 - b) To reduce risk of battery explosion, follow these instructions and those published by battery manufacturer and manufacturer of any equipment you intend to use in vicinity of battery. Review cautionary marking on these products and on engine.
- 12) **PERSONAL PRECAUTIONS**
 - a) Consider having someone close enough by to come to your aid when you work near a lead-acid battery.

- b) Have plenty of fresh water and soap nearby in case battery acid contacts skin, clothing, or eyes.
- c) Wear complete eye protection and clothing protection. Avoid touching eyes while working near battery.
- d) If battery acid contacts skin or clothing, wash immediately with soap and water. If acid enters eye, immediately flood eye with running cold water for at least 10 minutes and get medical attention immediately.
- e) NEVER smoke or allow a spark or flame in vicinity of battery or engine.
- f) Be extra cautious to reduce risk of dropping a metal tool onto battery. It might spark or short-circuit battery or other electrical part that may cause explosion.
- g) Remove personal metal items such as rings, bracelets, necklaces, and watches when working with a lead-acid battery. A lead-acid battery can produce a short-circuit current high enough to weld a ring or the like to metal, causing a severe burn.
- h) Use charger for charging a LEAD-ACID battery only. It is not intended to supply power to a low voltage electrical system other than in a starter-motor application. Do not use battery charger for charging non-rechargeable batteries that are commonly used with home appliances. These batteries may burst and cause injury to persons and damage to property.
- i) NEVER charge a frozen battery.

13) PREPARING TO CHARGE

- a) If necessary to remove battery from vehicle to charge, always remove grounded terminal from battery first. Make sure all accessories in the vehicle are off, so as not to cause an arc.
- b) Be sure area around battery is well ventilated while battery is being charged.
- c) Clean battery terminals. Be careful to keep corrosion from coming in contact with eyes.
- d) Add distilled water in each cell until battery acid reaches level specified by battery manufacturer. Do not overfill. For a battery without removable cell caps, such as valve regulated lead acid batteries, carefully follow manufacturer's recharging instructions.
- e) Study all battery manufacturers specific precautions such as removing or not removing cell caps while charging and recommended rates of charge.
- f) Determine voltage of battery by referring to car owner's manual and make sure that output voltage selector switch is set at correct voltage. Do not use the battery charger unless battery voltage matches the output voltage rating of the charger.

14) CHARGER LOCATION

- a) Locate charger as far away from battery as dc cables permit.
- b) Never place charger directly above battery being charged; gases from battery will corrode and damage charger.
- c) Never allow battery acid to drip on charger when reading electrolyte specific gravity or filling battery.
- d) Do not operate charger in a closed-in area or restrict ventilation in any way.
- e) Do not set a battery on top of charger.

15) DC CONNECTION PRECAUTIONS

- a) Connect and disconnect dc output clips only after setting any charger switches to "off" position and removing ac cord from electric outlet. Never allow clips to touch each other.
- b) Attach clips to battery and chassis as indicated in 16(e), 16(f), and 17(b) through 17(d).

16) FOLLOW THESE STEPS WHEN BATTERY IS INSTALLED IN VEHICLE. A SPARK NEAR BATTERY MAY CAUSE BATTERY EXPLOSION. TO REDUCE RISK OF A SPARK NEAR BATTERY:

- a) Position ac and dc cords to reduce risk of damage by hood, door, or moving engine part.
- b) Stay clear of fan blades, belts, pulleys, and other parts that can cause injury to persons.
- c) Check polarity of battery posts. POSITIVE (POS, P, +) battery post usually has larger diameter than NEGATIVE (NEG, N, -) post.

USER INSTRUCTIONS

AUTOMATIC CHARGING AND BATTERY STATUS MONITORING: Battery Tender® chargers are completely automatic and may be left connected to both AC power and to the battery that it is charging for long periods of time. The charger output power, voltage, and current depends on the condition of the battery it is charging. Battery Tender® chargers have several status LED indicators that provide a visual means to determine the operating mode of the charger and hence the condition of the battery connected to the charger.

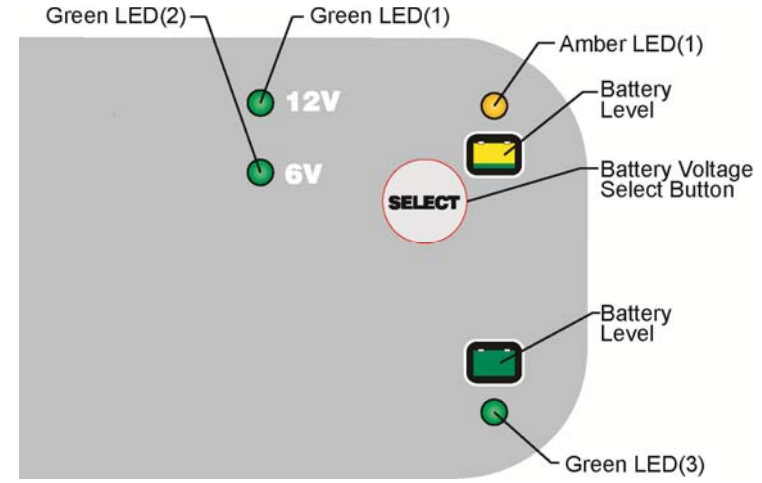

When AC power is first applied to the charger all of the LEDs will illuminate for two to three seconds before starting the charge sequence listed below.

The two battery level status LED indicator lights (Amber LED 1, Green LED 3) are available to determine whether the charger is operating in one of the four primary charge modes:

- 1) **Qualification/Initialization mode:** The Monitor Circuit verifies appropriate battery voltage levels and good electrical continuity between the battery and the charger DC output.
- 2) **Bulk mode** (full charge, constant current, battery is 0% to 80% charged)
- 3) **Absorption mode** (high constant voltage, battery is 80% to 100% charged).
- 4) **Storage/float maintenance mode** (low constant voltage, battery is 100% to 103% charged).

When the battery is fully charged, the battery level status Green LED(3) indicator will turn solid green and the charger will switch to a storage/float maintenance charge mode. The Battery Tender® charger will automatically monitor and maintain the battery at full charge.

- d) Determine which post of battery is grounded (connected) to the chassis. If negative post is grounded to chassis (as in most vehicles), see (e). If positive post is grounded to the chassis, see (f).
- e) For negative-grounded vehicle, connect POSITIVE (RED) clip from battery charger to POSITIVE (POS, P, +) ungrounded post of battery first. Then connect NEGATIVE (BLACK) clip to vehicle chassis or engine block away from battery. Do not connect clip to carburetor, fuel lines, or sheet-metal body parts. Connect to a heavy gage metal part of the frame or engine block.
- f) For positive-grounded vehicle, connect NEGATIVE (BLACK) clip from battery charger to NEGATIVE (NEG, N, -) ungrounded post of battery first. Then connect POSITIVE (RED) clip to vehicle chassis or engine block away from battery. Do not connect clip to carburetor, fuel lines, or sheet-metal body parts. Connect to a heavy gage metal part of the frame or engine block.
- g) Connect charger AC cord to electrical outlet.
- h) When disconnecting charger, turn switches to off, disconnect AC cord, remove clip from vehicle chassis, and then remove clip from battery terminal.
- i) See operating instructions for length of charge information.

17) FOLLOW THESE STEPS WHEN BATTERY IS OUTSIDE VEHICLE. A SPARK NEAR THE BATTERY MAY CAUSE BATTERY EXPLOSION. TO REDUCE RISK OF A SPARK NEAR BATTERY:

- a) Check polarity of battery posts. POSITIVE (POS, P, +) battery post usually has a larger diameter than NEGATIVE (NEG, N, -) post.
- b) Attach at least a 60cm (24-inch) long 6-gauge (AWG) insulated battery cable to NEGATIVE (NEG, N, -) battery post.
- c) Connect POSITIVE (RED) charger clip to POSITIVE (POS, P, +) post of battery.
- d) Position yourself and free end of cable as far away from battery as possible – then connect NEGATIVE (BLACK) charger clip to free end of cable.
- e) Do not face battery when making final connection.
- f) Connect charger AC cord to electrical outlet.
- g) When disconnecting charger, always do so in reverse sequence of connecting procedure and break first connection while as far away from battery as practical.
- h) A marine (boat) battery must be removed and charged on shore. To charge it on board requires equipment specially designed for marine use.

- *This appliance can be used by children aged from 8 years and above and persons with reduced physical, sensory or mental capabilities or lack of experience and knowledge if they have been given supervision or instruction concerning use of the appliance in a safe way and understand the hazard involved.*
- Children shall not play with the appliance. Cleaning and user maintenance shall not be done by children without supervision.
- The supply cord cannot be replaced. If the cord is damaged the appliance should be scrapped.
- Examine the battery charger regularly for damage, especially the cord, plug and enclosure; if the battery charger is damaged, it must not be used until it has been repaired.



This symbol indicates separate collection for electrical and electronic equipment

BATTERY VOLTAGE SELECT BUTTON

The Battery Tender® charger has a “SELECT” button which allows you to switch between charging a 6-volt battery or a 12-volt battery.

The battery voltage can be selected once the charger has AC power applied and before the charger is connected to the battery.

Once the charger has AC power and is also connected to the battery the voltage (12V or 6V) selection cannot be changed. To change the mode, disconnect the battery from the charger.

If the AC power is interrupted the charger will resume charging at the last battery voltage setting used.

The charger can also detect if the incorrect battery voltage has been selected once the connection has been made to the battery. One of the Green LEDs (LED 1 or 2) located next the 12V or 6V symbol will flash preventing the charge cycle from starting. In order to begin a new charge cycle, reset the charger by disconnecting it from the AC supply as well as the wrong or defective battery for 7-10 seconds. Reconnect the AC supply and the charger will be ready for a new charge cycle.

ATTENTION: The Battery Tender® CHARGER HAS A SPARK FREE CIRCUITRY. The output alligator clips or ring terminals will not spark when they are touched together. The Battery Tender® charger will not produce an output voltage until it senses at least 3 volts from the battery. It must be connected to a battery with the correct polarity before it will start charging a battery. Therefore, if you plug the AC power cord into an AC power outlet, and if the output alligator clips or ring terminals are not connected to a battery, and if you touch the alligator clips or ring terminals together, there will be no electrical spark.

NOTE:

THE OUTPUT CLIPS OR RING TERMINALS MUST BE CONNECTED TO A BATTERY BEFORE THE CHARGER CAN PRODUCE AN OUTPUT VOLTAGE.

TIME REQUIRED TO CHARGE A BATTERY:

The Battery Tender® charges at a rate of 1.25 Amps or 1¼ Amp-hours per hour. Therefore, a fully discharged 15 Amp-Hour battery will take approximately 9½ hours to recharge to 80% capacity.

WORKING WITH A DEAD BATTERY OR A BATTERY WITH A VERY LOW VOLTAGE:

If you try to charge a dead battery having a voltage below 3 volts, the Battery Tender® charger will not start. An internal safety circuit prevents the charger from generating any output voltage unless it senses at least 3 volts at the charger output. In this situation, the amber LED will continue to flash, indicating that a charge has not been initiated.

NOTE:

If a 12-volt, lead-Acid battery has an output voltage of less than 9 volts when it is at rest, when it is neither being charged nor supplying electrical current to an external load, there is a good chance that the battery is defective. As a frame of reference, a fully charged 12-volt, lead-Acid battery will have a rest-state, no-load voltage of approximately 12.9 volts. A fully discharged 12-volt, lead-acid battery will have a rest-state, no-load voltage of approximately 11.4 volts. That means that a voltage change of only 1.5 volts represents the full range of charge 0% to 100% on a 12-Volt, lead-acid battery. Depending on the manufacturer, and the age of the battery, the specific voltages will vary by a few tenths of a volt, but the 1.5-volt range will still be a good indicator of the battery charge %.

STATUS INDICATING LIGHT: If the light is not lit, then the battery is not properly connected and/or the charger is not plugged into AC power. The following describes light operation:

- < **AMBER LIGHT FLASHING** (Amber LED 1) – The amber LED flashing indicates that the battery charger has AC power available and that the microprocessor is functioning properly. If the amber LED continues to flash, then either the battery voltage is too low (less than 3 volts) or the output alligator clips or ring terminals are not connected correctly.
- < **AMBER LIGHT ON STEADY** (Amber LED 1) – Whenever the amber LED is on steady, a battery is connected properly and the charger is charging the battery. The amber LED will remain on until the charger completes the charging stage.
- < **GREEN LIGHT FLASHING** (Green LED 3) – When the green LED is flashing and the amber LED (Amber LED 1) is solid the battery is greater than 80% charged and may be removed from the charger and used if necessary. Whenever possible, leave the battery on charge until the green light is solid.
- < **GREEN LIGHT ON STEADY** (Green LED 3) – When the green LED burns steady, the charge is complete and the battery can be returned to service if necessary. It can also stay connected to maintain the battery for an indefinite period of time

TROUBLESHOOTING

- 1) If the charger does not turn on and none of the LEDs illuminate.
 - a. Check to make sure the AC outlet is supplying power by plugging in a lamp, an appliance, or a voltage meter.
- 2) The green LED (3) comes on immediately when charging a discharged battery.
 - a. The battery is probably defective, take the battery to the dealer to be tested.
- 3) When charging a battery the green LED never comes on.
 - a. The battery may be defective, take the battery to the dealer to be tested.
 - b. The battery has an excessive current draw, remove or disconnect the battery from the equipment.
- 4) The amber LED continues to flash even with a connection to the battery:
 - a. Check the fuse in the accessory cable.
- 5) 12V green LED is flashing.
 - a. The battery is damaged or the incorrect battery voltage has been selected.
- 6) 6V green LED is flashing.
 - a. The battery is damaged or the incorrect battery voltage has been selected.
- 7) Amber and Green LED are toggling.
 - a. Reverse polarity connection to the battery.
 - b. The chargers safety timer has activated due to the battery not reaching its optimal voltage. The battery may be defective, take the battery to the dealer to be tested.

FCC Warning

Title 47 Subpart, 15.105(b)

Note: This equipment has been tested and found to comply with the limits for a class B digital device, pursuant to part 15 of the FCC Rules. These limits are designed to provide reasonable protection against harmful interference in residential installation. This equipment generates, uses and can radiate radio frequency energy and, if not installed and used in accordance with the instructions, may cause harmful interference to radio television reception, which can be determined by tuning the equipment off and on, the user is encouraged to try to correct the interference by one or more of the following measures:

- Reorient or relocate the receiving antenna.
- Increase the separation between the equipment and receiver.
- Connect the equipment into an outlet on a circuit different from that to which the receiver is connected.
- Consult the dealer or an experienced radio/TV technician for help.